



Please read this manual attentively before installation

SONDAR

Contents

ABOUT THIS MANUAL	4
I. SAFETY GUIDE INSTRUCTION	6
1. Authorized Personnel.....	6
2. Operation.....	6
3. Cautions	6
4. Product Inspection	6
5. Symbols.....	7
II. PRODUCT.....	9
1. Principle of operation.....	10
2. Specification.....	11
3. Product Package	12
4. Dimension	12
III. INSTALLATION	14
1. General Guide	14
2. Mounting	15
3. Installation Condition	17
IV. WIRING	19
1. Wiring.....	19
2. Power.....	20
V. OPERATION	22
1. Start-up Display	22
[Pic1. Start-up Display]	22
[Pic2. Start-up Display].....	22
2. Display.....	23
3. Buttons.....	25

VI. PROGRAMING.....	28
1. Application Menu	28
2. Current Output Menu	30
3. Compensation Menu	32
4. Outputs Simulation Menu	35
5. Password Menu	36
VII. MAINTENANCE.....	38
Warranty Period.....	38
Repair Service.....	38
VIII. TROUBLE SHOOTING	40

About this Manual

This manual provides important information about the installation, wiring, operation, and control of ULM-200C. Please read this manual before installing or operating the product. In addition to operating the product, this manual is very important. Please keep it in a safe place for easy reference.

This manual is provided an electronic version only. The electric version is provided with the product package or it can be downloaded through our website (www.sondar.com).

Please note that the contents of this manual are subject to change without prior notice if the product is modified, upgraded or improved.

Although we have checked all contents of this manual but there would be the possibility to remain errors. Therefore the contents of this manual are regularly updated. We welcome all suggestions for improvement.

SONDAR is a registered trademark of IS Technologies Co., Ltd.

Without our prior written permission, reproduction, distribution or any use of manual contents are strictly prohibited.

Copyright IS Technologies Co., Ltd. 2013. All right reserved.

Safety Guide Instruction

I. Safety Guide Instruction

1. Authorized Personnel

The installation and operation of the product must be carried out by licensed experts or qualified personnel. Please always wear protective equipment when operating the products.

2. Operation

Before operating the unit, please read this manual thoroughly. The manufacturer isn't responsible for accidents caused by user's misuse or modification of the product without manufacture's permission. Conduct periodic inspection of the product.

3. Cautions

This manual provides all information you need to operate ULM-200C, maintain and trouble shoot. Please follow the instructions in this manual. The manufacturer is not responsible in any way for the risk of an accident when user doesn't follow the instructions.

4. Product Inspection

When opening the product package box, look carefully to determine if the products or accessories have been damaged or contaminated. If the product has been damaged, it may not function properly.

5. Symbols



Caution:

If it is ignored, faults or malfunctions could be result.



Warning:

If it is ignored, injury to people and serious damage to the instrument could be result.



Electric Shock

If it is ignored, the product could be damaged by electric shock



Information:

It provides additional information.

Product Description

ULM-200C

II. PRODUCT

ULM-200C is an ultrasonic non-contacting level meter designed sensor and transmitter in one housing by an explosion-proof structure. The easurement range is 8 meters. It is two-wire loop-powered product.

The sensor material is PVDF so it can be applied in various industry applications. Its simple maintenance expects economical effect of managing facilities.

The accurate level and reliable performance enable you the effective level monitoring and your facilities running safely and consistently.

Application:

ULM-200C is suitable for liquids level monitoring in all industries, particularly in the water and wastewater industry.



- Depending on the sensor material, the application can be restricted. Before installing the sensor, please check the chemical compatibility chart.

1. Principle of operation

The sensor transmits ultrasonic pulses to the measurement target. The pulses are reflected from the surface of the target and received back by the sensor. The running time is converted into the distance and it shows as level or volume on the display.

$$D=(C \cdot T) / 2$$

D: DISTANCE

C: SOUND VELOCITY

T: TIME OF FLIGHT

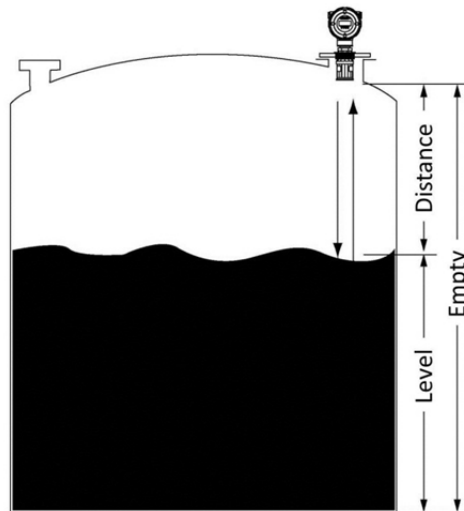

- Distance: from the sensor bottom to surface of the target
- Level: from the bottom of storage to surface of the target
- Empty: from the sensor bottom to the bottom of storage

2. Specification

ULM-200C	
Measurement	Ultrasonic non-contacting
Measuring Range	0.3 to 8.0m (0.98 to 26.2ft)
Accuracy	0.2% of F.S
Beam Angle	8° at -3dB
Resolution	1mm or 0.03% of F.S
Damping Rate	0.01m/min - 100m/min adjustable
Output Analog	Analog 4~ 20mA, into max 600Ω
Display	5 Digit LCD
Material	Polypropylene
IP Rating	IP67
Process Connection	2 ½" NPT
Temperature	-20 ~ 70 (-4 ~ 158) for Sensor -20 ~ 60 (-4 ~ 140) for LCD
Temperature Compensation	by a built-in temperature sensor
Dimension	130(W)× 187(H)× 287(D) mm
Weight	ca. 2.8kg
Power Supply	DC 20~ 30V
Power Consumption	less than 0.022A

* The Specification is subject to change without prior notice.

3. Product Package



ULM-200C



Manual CD



1/2 inch Nipple

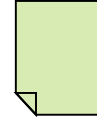

Test Report

4. Dimension

The enclosure material is polypropylene and the protection grade is IP67.

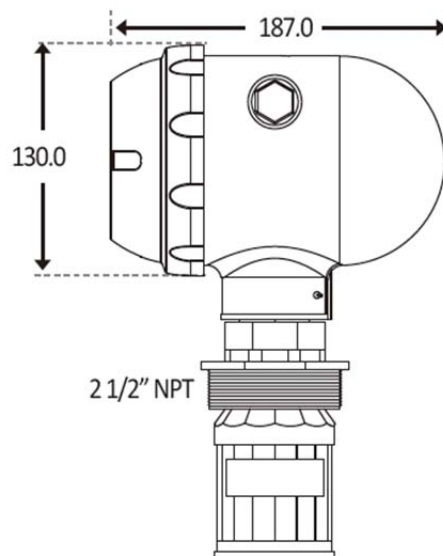
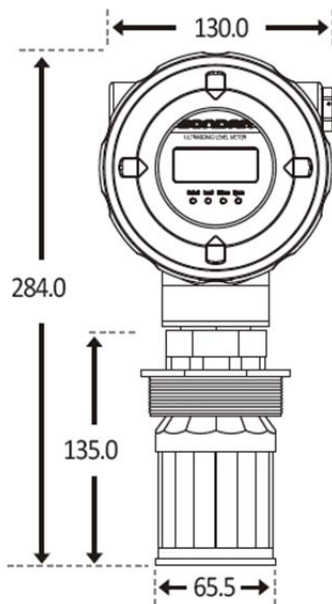

INSTALLATION

III. Installation

1. General Guide

Before installing the product, read this manual and specification. It is installed in a place that is within the temperature range specified in this manual and that is suitable to the enclosure rating and materials. If the products are installed improperly, it may cause malfunction.

This is general guide for installing SONDAR ultrasonic products.

- ✓ Remove the obstacles in the space between the sensor and the measured target such as ladders, limit switches, heating spirals etc.
- ✓ When mounting the sensor, keep the distance to the vessel wall.
- ✓ The bottom of the sensor should be perpendicular to the surface of water.
- ✓ Do not set the maximum level into the Dead Zone range.
- ✓ Avoid the intense winds and excessive exposure to direct sunlight. The strong winds change the path of ultrasound and may cause a malfunction. If you need to install the unit in a spot exposed to direct sunlight, sun screen must be installed.
- ✓ Keep the distance from the place where are strong noise by high voltage, high current etc.
- ✓ Install the unit in the place vibration free.
- ✓ Use the product in accordance with its specifications.

2. Mounting

ULM-200C can be mounted with a mounting bracket or with screw in flange or in many other ways. This manual explains two typical mounting types of ULM-1000C.

2-1. Installation with mounting bracket

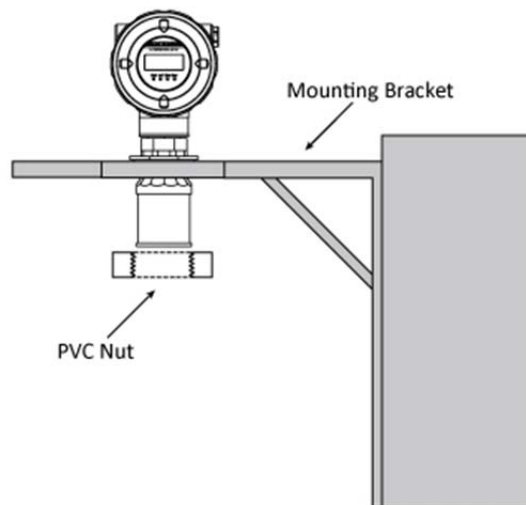

- If the equipment is installed or used in a manner not specified in this manual, then the protection provided by the equipment may be impaired.

2-1. Installation with screw in a flange

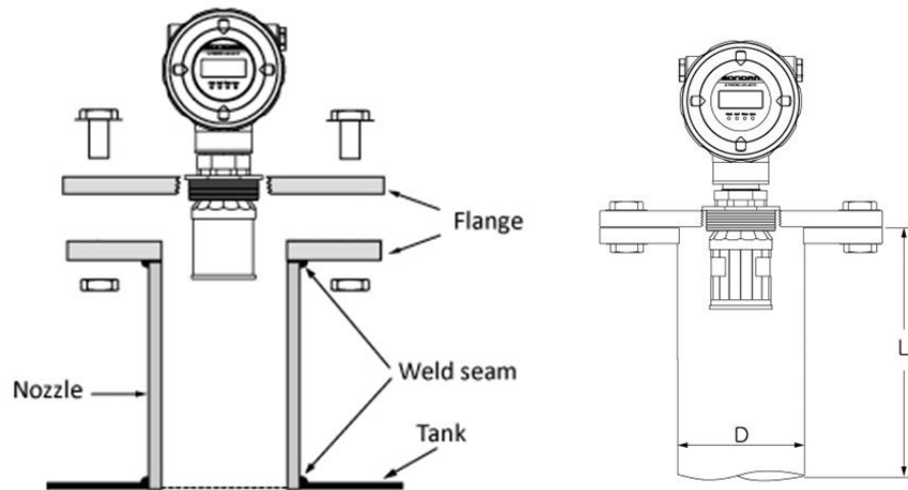

Nozzle Diameter(D)	Maximum Nozzle Length(L)
80mm	240mm
100mm	300mm
150mm	430mm
200mm	570mm



- The nozzle length shouldn't be exceeded the maximum length above. Shorter setting is better.
- The nozzle should be free of obstructions such as weld seams.

3. Installation Condition

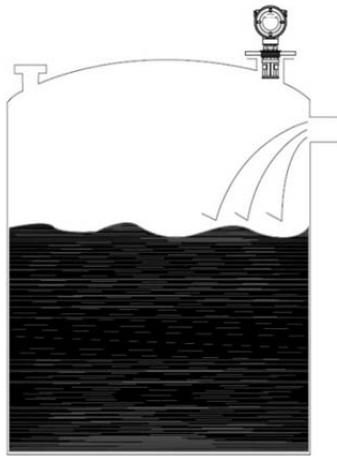

Do not install the sensor in or above a filling flow outlet. Secure enough distance from the filling flow.

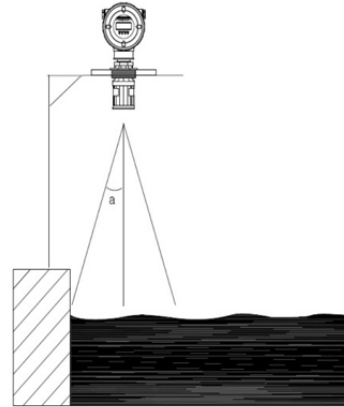

When mounting the sensor, keep the distance to the vessel wall.

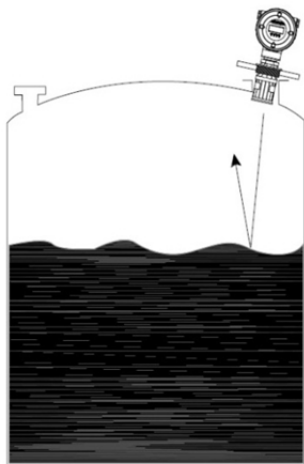

The bottom of the sensor should be perpendicular to the surface of water.

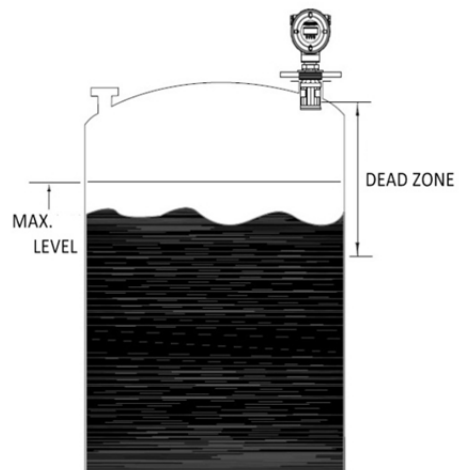

Do not set the maximum level(100% of Span) into the Dead Zone range

Wiring

IV. Wiring

1. Wiring

The ULM-200C Series terminal connection is as detailed below. Wiring details are also given on the terminals under the access cover.

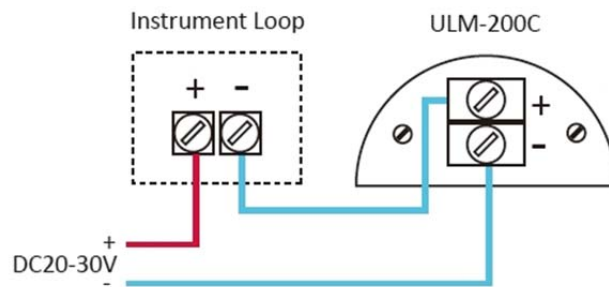
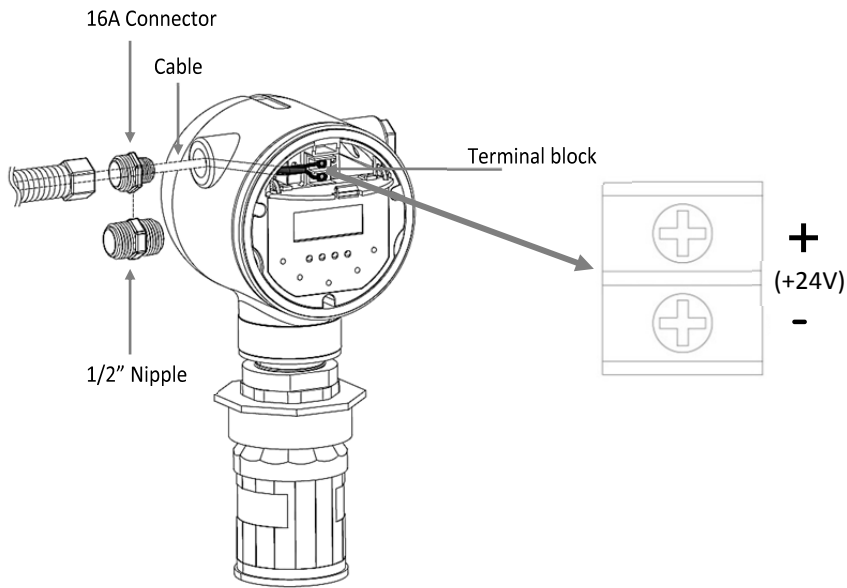

- If the equipment is installed or used in a manner not specified in this manual, then the protection provided by the equipment may be impaired.

2. Power

The standard power type is DC power. The power range is DC20-30V.



- When turning on the power of ULM-200C for the first time, make sure any connected devices are disabled until all system functions are confirmed and to be operating properly.

Operation

V. Operation

1. Start-up Display

When ULM-200C is powered on, the screen shows as bellow pictures. After showing Pic2, the actual level value is displayed on the display screen.



[Pic1. Start-up Display]



[Pic2. Start-up Display]

2. Display

2.1 LCD DISPLAY

ULM-200C has two modes for measuring level. Measuring Mode is to show the measuring value in real time while it is operating. Programing Mode is to calibrate the menus for individual applications.

The 4 digits are shown in the LCD in the Measuring Mode. A Flaſhing “0” is shown when it is in fault condition (Lost Echo).

The program number is shown in the LCD in the Programing Mode such as P01, P02 etc.

The “menu” button is used to switch each mode.



2.2 LED Functions



There are 4 LED's, located above the display their functions are as follows:

LED	Condition	Function
Detect & Level	Flashing together	Indicates Normal Operation Mode selected = Level
Detect & Distance	Flashing together	Indicates Normal Operation Mode selected = Distance
Detect & Space	Flashing together	Indicates Normal Operation Mode selected = Space
Detect	Flashing alone	Indicates that ULM-200C is detecting an echo but checking if the value is correct. The reasons
None	All Off Display indicates flashing "E*"	Indicates that ULM-200C has gone into Fail condition. E0 means there is no reflected echo received. E1 means transducer and

2.3 Measuring Mode

This mode is used once the ULM-200C has been set up in program mode. It is also the default mode that the unit reverts to when it resumes operation after a power failure.

When the ULM-200C is switched on for the first time, it will display, in centimeters, the distance from the transducer face to the target.

After programming is complete, any switched outputs that are set will operate when the level reaches the relevant setpoint. Whilst in Run Mode the Detect and Distance LED's provide information on the status of the signal.

2.4 Programing Mode



This mode is used to set up the ULM-200C or change information already set, this is achieved by using the 5 push buttons located either side of the display.

Entering a value for each of the menu options that are relevant to your application provides all the programming information.

The menu number is displayed with alphabet "P". Up and Down Key makes move to another menu.

3. Buttons

To access the Program Mode simply press the "Mode" button. Confirmation that you have entered the Program Mode will be given by the Detect and Mode (Level, Distance, Space) LED's being extinguished, and the Software Version will also appear in the display. Each subsequent press of the Mode button will advance you through the options, 01 to 05. To access other group options, you have to press the Mode and Up/Down buttons.



- Move to setting menu
- Start to change the setting value
- Position change of setting value



- Complete the setting



- Close the setting
- Move to the upper menu



- Move up at the menu
- Change the setting value



- Move down at the menu
- Change the setting value

Example of using buttons

[Example] When the bottom distance value is changed from 10meter to 9meter,



- Press “MENU” button for 1 second in measuring mode.



- Software version displays for 2 second.



- After showing the S/W version, the menu number displays.



- Use “UP” and “DOWN” button go to P04.



- Press “menu” button, the first digit flickers. With “UP” and “DOWN” button, the number is changed.



- After first digit setting, press “MENU” button to move the second digit.



- After all setting, press “RUN” to save the value. it returns to measuring mode.



- If press “ESC” button instead of “RUN” button, it returns to the menu which you selected right before. The setting value isn’t saved.

Programing

VI. Programming

This chapter describes all of the menu options in ULM-1000C, in numerical order. Press the menu button, can be set the menu option. From menu 1 to menu 18 it can be moved with up or down key. The grey marked cell is the factory set value.

1. Application Menu

[P01] Measurement

This option sets the variable of measurement when in measuring mode, and can be set to one of the following:

Option	Value	Description
1	Level	Display shows how full the vessel is with respect to the Empty (0% of Span)
2	Distance	Display shows the distance from the transducer face to the surface.
3	Space	Display shows how an empty vessel is with respect to Full (100% of Span) i.e. how much space is available in the vessel.

[P02] Measuring Unit Selection

This option is to choose the measuring unit between meter and feet.

Option	Unit
1	Meter
2	Feet

[P03] Display measuring value

This option sets the display unit of LCD display among 1. meter(feet), 2. mA, or 3. %

Option	Unit
1	Distance by selected measuring unit
2	mA (Current value)
3	% (Percentage)

[P04] Empty Distance

This option is to sets the maximum distance from the face of the transducer to the bottom distance, in cm (inch). The tank has to be empty. User can set factory set value with up and down keys. The maximum set value is 600 for ULM-10C-X06, 1000 for ULM-10C-X10.

Setting range	Default
0. 30~99.99m	6.00m



- The setting value of the bottom distance is mostly maximum measuring range of the sensor. However, the bottom distance could be set as 99.99m depending on the application conditions. The incorrect bottom distance value causes the incorrect measurement.

[P05] Dead Zone

This option is the distance from the face of the transducer that is not capable of being measured, and is pre-set to 30cm (12 inches). It should not be set to less than this figure, but can be increased if required.

Setting range	Default
0. 30~99.99m	0.3m



A DEAD ZONE of 30cm should be excepted when setting 20mA OUT. If the level approaches in the DEAD ZONE, It might be displayed incorrect measurement value instead of the actual measurement level.

2. Current Output Menu

[P06] 4 mA Setpoint

The range of current is from 4mA to 20mA. This option sets the distance (or level or space, depending on the selected **Operating Mode (Option 01)** at which the 4mA output will occur. By default 4mA will represent **Empty** (0% of Span)

[P07] 20 mA Setpoint

The range of current is from 4mA to 20mA. This option sets the distance (or level or space), depending on the selected **Operating Mode (Option 01)** at which the 20mA output will occur. By default 20mA will represent **Full** (100% of Span). If you set the lowest point as 20mA, 4mA should be set for highest point.



- The Span is the maximum working distance from Empty (0%) to Full (100%), and is automatically calculated as Empty Level (P04) minus Blanking Distance (P05). Except for when Measurement (P01) is selected as Distance in this case the Span is the same as the Empty Level (P04)

[P08] mA Fail-safe Value

When the instrument is installed incorrectly or the transducer is broken, it can't be measured continuously. If the ULM-200C Series fails to receive a valid echo return from the target, then the mA output can be used to indicate a fault condition (Loss of Echo). This option determines the mA output value which will indicate such a condition.

Option	
1	3.8 mA: Fault condition (LOE) indicated by 3.8mA
2	Hold: The previous measured value outputs
3	22mA: Fault condition (LOE) indicated by 22mA % (Percentage)

[P09] mA Fail-safe Time

In the event of a fail-safe condition occurring (LOE) the fail safe timer determines the time before the mA output indicates a fault condition (LOE). For a while the instrument keep measuring by detecting the signal but when it fault condition stays for fail-safe time, it regards it is an error. The time range is between 20 second and 900 second. The pre-set is 300 second.

3. Compensation Menu

[P10] Damping Rate

The measured value is not displayed in real time. The value is generated by average for certain time. It can be more effective for accurate value. But when the level is changed dramatically, it can be inaccuracy. For getting accurate level, choose the suitable damping rate in accordance with the velocity of level. The pre-set is “1.”

Option		Description
0.01	0.01m/min	Responds to changes to a max. 0.01m/min (Slow)
Step: 0.01		Minimum: 0.01 - Maximum: 100.0
100.0	100m/min	Responds to changes to a max. 100m/min (Fast)

[P11] Detection Threshold Voltage

This option determines detectable size of return echo. This is useful when the first return echo is needed in condition where small objects creating various kinds of return echoes exist. In case the set value is high, it can be stronger to the noise, but may not be able to detect small echoes. The 8 is equal to 0.8V. The table below shows the equivalent voltage to each value. The pre-set is “3.”

No.	3	4	5	6	7	8	9	10	11	12	13	14	15
Voltage	Low						High						

[P12] Output Power

This option is used to set the power output from the transducer to suit varying applications.. By reducing the power emitted the beam angle will be effectively reduced and can be applied as detailed below:

Option	Level	Description
1	Low Power	For use on short range applications
2	Normal Power	For use in normal conditions
3	High Power	For use in outdoor applications, long range measurement
4	Maximum Power	For use in arduous applications where conditions are dusty, steamy or turbulent.

[P13] Sound Velocity

This option allows for the velocity of sound to be changed according to the atmosphere the transducer is operating in. By default the velocity is set for sound travelling in air at a temperature of 0°C.

The table below gives details of the velocity of sound in various gaseous atmospheres in all cases the velocity indicated is that in a 100% gaseous atmosphere at 0°C. In atmospheres less than 100% it may be necessary to check the level indicated at near empty and near full and compare with the actual level, several times, then adjust the **Sound Velocity** accordingly to obtain an accurately displayed reading.

Name of Gas	Sound speed (m/sec)
Chlorine	206
Carbon dioxide	259
Argon	308
Oxygen	316
Air	331.5
Ammonia	415
Ethane	430
Neon	435
Helium	965

[P14] Vapor Temperature Compensation

The sound velocity in air increases or decreases at a uniform rate of 60cm/°C, however in atmospheres other than air it will change at a different rate. This option allows the rate of change in cm/°C to be set according to the present atmosphere and temperature. The level indicated, should be compared with the actual level, several times, then **Vapor Temperature Compensation** adjusted accordingly, to obtain an accurately displayed reading. The pre-set is 60cm/°C.

[P15] Detection Algorithm

This option determines the detection algorithm. The returned signal can be strong or weak according to field condition. This option chooses what signal is effective.

Option	Description
1	Automatic
2	Effective only for the First signal

[P16] Detection Target

The signals reflectance is subject to change by the measuring target.

Option	Description
1	Liquid
2	Bubble Liquid
3	Solid
4	Powder

4. Outputs Simulation Menu

When ULM-200C is operated with other instruments, this menu can test to examine by the output current from ULM-1000C. This is for the simulation.

[P17] Simulation

Put the range at your disposal. ULM-200C sends out the output current for the range. For example, if you put 6 meter (0.600), the output current is sent out respond to 6 meter. If the range value is over than lowest level or highest level, the error signal is sent out. When you move to the CURRENT SIMULATION menu, the measuring process is stopped and the current output becomes initialized to 0.

5. Password Menu

[P18] Password

This option prevents malicious and unskilled user from changing option values. Once this option is set, the password is required whenever entering into program mode. The initial password is "0."



1. If the password is not "0", the "pass" shows on the display.



2. After 1 second, it moves to setting mode automatically. The first digit flickers. Use "UP" and "DOWN" button to set the password. Use "MENU" button to move the digit position.



3. After setting password, press "RUN" button, the password is saved and return to the program mode.



4. When the password is incorrect, the error message shows on the display. After 1 second it returns to setting password mode.



- User can't configure the menus when user forgets the password. Please note password number and pay attention not to lose it.

Maintenance

VII. Maintenance

Regular Inspection

- There are no contaminants on the surface of sensor.
- Current output is working in the normal range of 4-20mA.
- Value displayed at the screen is same as actual level value.
- Rating power supply is approved.

Warranty Period

Warranty period is 3 years for ULM-200C but if the problem is caused by user's fault or misuse, the repair charge will be incurred.

Repair Service

When some problem is occurred in ULM-1000C, the error code displays on the screen, it shows what the problem is. The error code information can be founded in this manual. Even though conduct every process by the trouble shootings in the manual, still the problem exists, contract an official distributor or SONDAR customer center.

When the product is sent for the repair, the repair request form has to be filled out and enclose it with the products.

Despite of being in warranty period, if the problem is caused by user's fault or misuse, the repair charge will be incurred.

Trouble shooting

VIII. Trouble shooting

When some problem is occurred in ULM-1000C, the error code displays on the screen, it shows what the problem is. The error code information can be founded in this manual.

1. The level changes heavily periodically

Cause: Motor or alternator is installed.

- 1) Set the velocity lower than current setting value or
- 2) The level should be moved to another position where is not effected from the machinery.

2. The level changes irregularly

Cause: Barrier within the ultrasonic range.

- 1) Set the velocity lower than current setting value or
- 2) Set the Detection Threshold Voltage lower than current voltage or
- 3) Check the sensor bottom surface if there is any foreign debris or pollution.

3. The level shows only within blanking distance

Cause: Error by the protrusions in the nozzle of reservoir.

- 1) Check the nozzle inside surface or
- 2) Check the nozzle diameter which is recommended in the manual or
- 3) Increase the blanking distance not over the highest level point.

4. The level is incorrect in the sealed space.

Cause: The pressure is increased by gas generation.

1. set the sound velocity according to the medium or
2. Install ventilation.

ULM-200C Menu List

Program No.	Menu	Range	Factory Set	Note
Application	P01	Measurement	1. Level 2. Distance 3. Space	Distance
	P02	Unit	1. meter 2. feet	meter
	P03	Display	1. Level 2. mA 3. %	level
	P04	Bottom Distance	0.000 ~ 9.000m	8.000m
	P05	Dead Zone	0.300 ~ 8.000m	0.300m
Current Output	P06	4mA Output	0 ~ 9.000m	0
	P07	20mA Output	0 ~ 9.000m	8.000m
	P08	Error	1. 3.8mA 2. Hold 3. 22mA	22mA
	P09	mA Fail-safe Time	20-900sec	300sec
Compensation	P10	Damping Rate	0.01-100/min	1m/min
	P11	Threshold	3(Low) – 15(High)	3(Low)
	P12	Output Power	1(Weak) – 4(Strong)	2
	P13	Sound Velocity	150-500	331.5m/s
	P14	Vapor Temperature Compensation	-200 ~ 200	60cm/°c
	P15	Detection Algorithm	1. Automatic 2. Effective only for the first signal	Automatic
	P16	Detection Target	1. Liquid 2. Bubble Liquid 3. Solid 4. Powder	Liquid
Output Simulation	P17	Simulation	0.000-9.000	
Password	P18	Password	0-9999	0

IS Technologies Co., Ltd.

11-78 Songdo-dong Yeonsu-gu, Incheon-City,406-840,
Republic of Korea
Phone: +82 32 850 2624 Fax: +82 32 850 2612
Email. sales@sondar.com

©IS Technologies Co., Ltd. 2013.